



# Delser®

1891



With 5 vitamins,  
calcium and iron  
Riche en 5 vitamines,  
calcium et fer



From 6<sup>th</sup> month  
Dès 6 mois

# Baby Biscuit

Poids net / Net Wt.  
180g / 6.35 oz



L'immagine ha il solo scopo di presentare il prodotto - serving suggestion  
L'immagine ha il solo scopo di presentare il prodotto - suggerimento di presentazione

Dal 6° mese  
Con 5 vitamine,  
calcio e ferro  
Facilmente solubile



From 6<sup>th</sup> month  
Source of iron and  
vitamins of group B  
Easily soluble

# Baby Biscuit 180g



# Baby Biscuit

## Biscotto per l'infanzia con 5 vitamine, calcio e ferro Soluble biscuits for infant feeding with 5 vitamins, calcium and iron

I Baby Biscuit Delser nascono da ingredienti selezionati e controllati e sono arricchiti con calcio ferro e vitamine del gruppo B. Sono indicati a partire dal 6° mese e possono essere consumati a colazione, come spuntino o merenda. I biscotti per l'infanzia Delser sono facilmente solubili e quindi ottimi per essere sciolti nel latte tiepido, in succo di frutta o in infusi e tisane; sono ideali anche da soli perché la loro forma allungata è particolarmente adatta alle manine del bambino.

Il Baby Biscuit Delser è disponibile in 3 astucci fra loro diversificati per soddisfare i diversi mercati mondiali.

*Delser Baby Biscuits are made with selected and tested ingredients and they are enriched with iron and vitamins group B. They are indicated from the 6th month onward and they can be eaten for breakfast or as a snack. Delser Baby Biscuits are easily soluble so they can be dissolved in warm milk, fruit juice or infusions and herbal teas; they are very good also alone, as their shape is especially suitable to babies' little hands.*

*The Baby Biscuit Delser is available in 3 different packagings to satisfy the several markets regulations worldwide.*

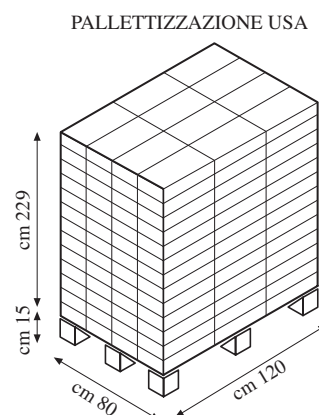
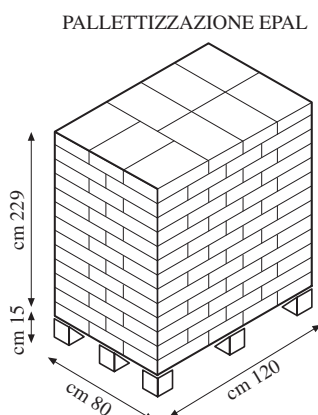
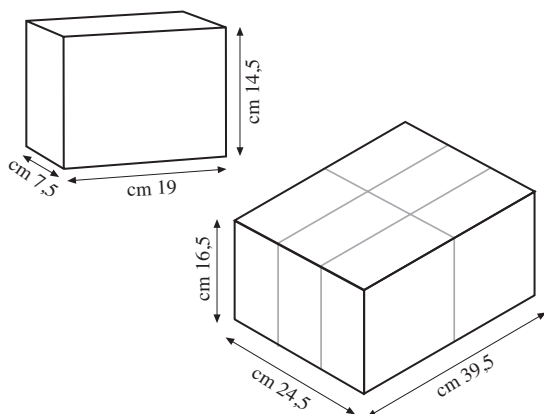

CODICE AZIENDALE - ITEM N.	0785	0786	0787
CODICE EAN - EAN CODE	8008910078500	8008910078616	8008910078715
DENOMINAZIONE ARTICOLO ARTICLE DENOMINATION	BABY BISCUIT (EUROPA)	BABY BISCUIT (CANADA)	BABY BISCUIT (USA)
PESO NETTO NET WEIGHT	GRAMMI		OZ
	180 g		6.35 oz
PEZZI PER CARTONE PIECES IN EACH CARTON	6		
PESO LORDO CARTONE CARTON GROSS WEIGHT	1,7 Kg - 3.75 lb		
VOLUME CARTONE - CARTON VOLUME	0,016 m <sup>3</sup>		
CARTONI PER PALLET A TERRA CARTONS PER PALLET (STACKED PALLET)	117 (in pallet Epal) - 156 (in pallet USA)		
SCADENZA - SHELF LIFE	15 mesi - months		

Norme di conservazione: Conservare in luogo fresco e asciutto - Preservation rules: Keep in a cool and dry place



Quality Food Group S.p.A. - Via Spilimbergo 221 - 33035 Martignacco (UD) - ITALY  
tel: +39 0432 638811 - fax: +39 0432 677152  
e-mail: info@qualityfoodgroup.com - web: www.qualityfoodgroup.com